

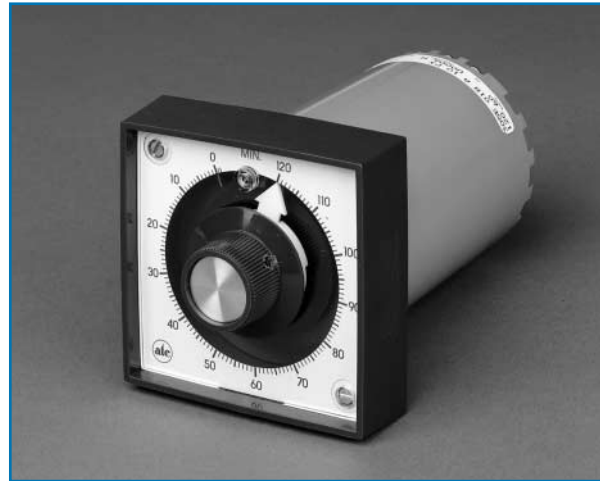

Motor-Driven Analog Reset Timer

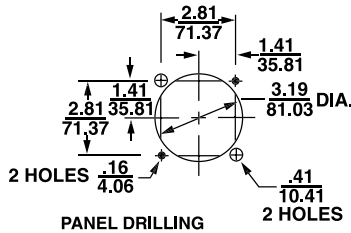
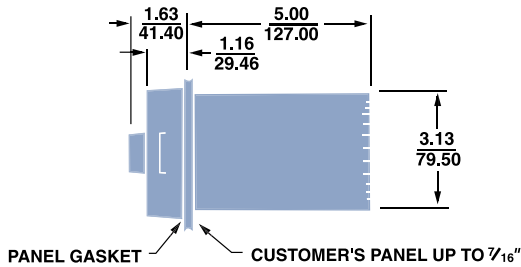
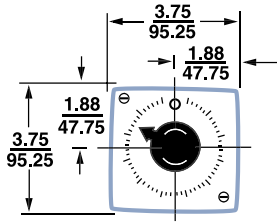

PRODUCT HIGHLIGHTS

HIGHEST ACCURACY

Because of its exclusive infinite engagement clutch, the 305 has a repeat accuracy of 0.2%, highest of any timer in its class.

PLUG-IN AND DUST-TIGHT DESIGN

By virtue of its true plug-in design, the body of a 305E can be replaced in seconds without disturbing the housing or disconnecting the wiring. Its gasketed dial assembly forms a dust-tight seal against the housing, whether panel or surface-mounted.

APPROVALS

See Agency Listing on page 391.

FASTEST RESET

All 305 timers reset to a full-scale setting within 0.1 second, proportionately faster for shorter settings.

CIRCUIT FLEXIBILITY

All the contacts of its two instantaneous and two delayed load switches are externally accessible at a 14 point terminal block.

LONGEST LIFE

With an average mechanical life expectancy of over 5,000,000 operations before the first failure, the 305 is the leader in its class.

PILOT LIGHT

A built-in pilot light indicates that the timer is running.

Noted for its circuit flexibility, the 305E also provides the highest accuracy among analog timers. Available for either ON-Delay or OFF-Delay operation.

The 305E provides delay, interval or pulse timing function for up to 7 load circuits through two instantaneous and two delayed switches. It features a plug-in design and cycle progress indication.

OPERATION

The 305 is a synchronous motor-driven timer with an electrically-operated clutch equipped either for **ON-Delay** or **OFF-Delay** operation.

ON DELAY

When power is applied (start signal **on**), the clutch solenoid is energized. Two things happen immediately and simultaneously, the instantaneous switches transfer from one set of contacts to the other, and the motor begins to drive the cycle progress pointer toward zero.

At the end of the timed period, the pointer trips one of the delayed switches, a brief time later (about 1/2% of full scale), the other delayed switch is tripped, stopping the timer motor but leaving the clutch engaged. The timer does *not* reset until power to the clutch is removed.

OFF DELAY

Timing starts when power is removed (start signal **off**), from the spring-loaded, normally engaged clutch. The timer is reset when power is restored to the clutch solenoid; simultaneously, the instantaneous contacts are tripped. Action of the delayed contacts is the same as with **ON-Delay** timers. A power outage stops the motor but does not reset the **OFF-Delay** 305.

		ON DELAY			
		TIMING SEQUENCE**			
SWITCH	CONTACTS	Before Start	During Cycle	*	End of Cycle
INSTANTANEOUS	14-9/6-8	Gray	Blue	Blue	Gray
	14-10/6-7	Blue	Gray	Gray	Blue
DELAYED (D ₂)	11-12	Blue	Blue	Blue	Gray
	11-13	Gray	Gray	Gray	Blue
DELAYED (D ₁)	4-5	Blue	Blue	Blue	Gray
	4-3	Gray	Gray	Gray	Blue

*D₂ trips approximately 1/2% of range after end of cycle.

** Assumes a sustained **closed** start signal (i.e. longer than the dial set time).

		OFF DELAY			
		TIMING SEQUENCE**			
SWITCH	CONTACTS	Before Start	During Cycle	*	End of Cycle
INSTANTANEOUS	14-9/6-8	Blue	Gray	Blue	Gray
	14-10/6-7	Gray	Blue	Gray	Blue
DELAYED (D ₂)	11-12	Blue	Blue	Blue	Gray
	11-13	Gray	Gray	Gray	Blue
DELAYED (D ₁)	4-5	Blue	Blue	Blue	Gray
	4-3	Gray	Gray	Gray	Blue

*D₂ trips approximately 1/2% of range after end of cycle.

** Assumes a sustained **open** start signal (i.e. longer than the dial set time).
Shown power on



BLUE—Circuit Closed



GRAY—Circuit Open

SPECIFICATIONS

MODELS

Choice of **ON-Delay** or **OFF-Delay** operation.

RANGES (AC)

16 standard ranges, from 6 sec to 60 hrs. at 60 Hz (7 sec to 70 hrs. at 50 Hz) other ranges on special order.

REPEAT ACCURACY

AC MODELS: ± 0.2% of full scale (For ranges of 60 sec or less, it may be necessary to run timer motor before *start* to achieve related accuracy).
DC MODELS: ± 1.75% of full scale at constant ambient temperature and ± 15% voltage variation (48, 125 and 250V models); ± 3.5% of full scale at constant voltage and 32 to 120°F ambient temperature variations (all models).

RESET TIME

0.1 sec., full scale.

MIN. SETTING

1/60th of range (all models except: 0.3 sec for 6 sec model).

DIAL DIVISIONS

6 sec., 60 sec., 120 sec., 240 sec., 6 min., 60 min., 120 min., 240 min., 6 hr., and 60 hr. -- 120 Dial Divisions
15 sec., 30 sec., 15 min., 30 min., 15 hr., and 30 hr. -- 150 Dial Divisions

LIFE EXPECTANCY

MECHANICAL: over 5,000,000 operations (average).
CONTACTS: 3,000,000 operations under resistive or inductive load of 1A

TIMING MOTOR

Synchronous, permanently lubricated

TIMING MODES

Single cycle interval or delay.

LOAD SWITCHES

INSTANTANEOUS: two, each SPDT; self-cleaning, heavy-duty silver contacts.
DELAYED: two, each SPDT; precision type, silver contacts.
CONTACT RATING (non-inductive):
10 amps, 120VAC
5 amps, 240VAC
1/4 amp, 115VDC.

PILOT LIGHT

Wired in parallel with motor; standard with all AC and DC models.

TERMINALS

14 screw terminals accessible at rear; integral wiring diagram on timer housing (On DC timers, terminal 10 is not available for load circuit use on units rated 48 volts DC or higher).

HOUSING

Plug-in design; completely gasketed, dust-tight when surface or panel-mounted.

POWER REQUIREMENTS

AC MODELS: 120 or 240V, 50/60 Hz (all ranges), (+ 10%, - 10%)
DC MODELS: 48, 125 or 250V with zener regulations; 28V without zener regulation.
AC MODELS:
running current--0.128 A (115 VAC).
inrush current--0.628 A (115 VAC).

TEMPERATURE RATING

32° to 140°F (0 to 60°C).

WEIGHT

NET: 2 lb., 6 oz.
SHIPPING: 2 lb., 12 oz.

MOUNTING ACCESSORIES

STANDARD: Hardware is provided to mount timer so that it is dust-tight from front of panel.
OPTIONAL: Surface mounting with front or rear-facing terminals. NEMA 12 (See Accessory Section of Catalog)

TYPICAL INSTALLATIONS

- CLUTCH SOLENOID
 - MOTOR
 - INDEPENDENT LOADS
 - DEPENDENT LOADS
 - MOMENTARY STARTING CONTACT
 - SUSTAINED STARTING CONTACT
 - LOAD ENERGIZED
 - LOAD DE-ENERGIZED
- All timers shown in "before start" position. Diagrams shown with power off unless otherwise marked.
- Maximum load current through any load carrying contact is 10 amperes.
- ON DELAY—Reset on power failure.
- OFF DELAY—Non-reset on power failure.
- DELAYED CONTACTS
 - Switch 4-5-3 transfers at dial "0". Switch 11-12-13 transfers 1% later.
 - INSTANTANEOUS CONTACTS
 - Contacts are transferred when clutch is energized; transferred back, as shown when de-energized.

MOMENTARY START (ON DELAY)

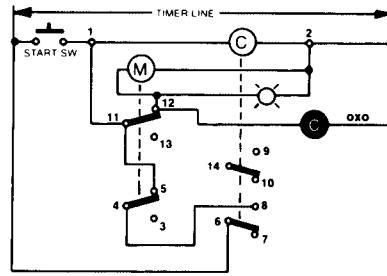

SUSTAINED START (ON DELAY)

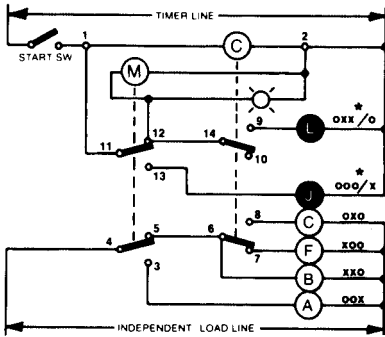

OFF DELAY

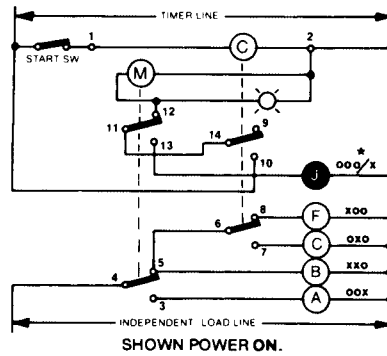

TERMINAL WIRING

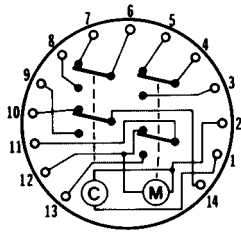

WIRING

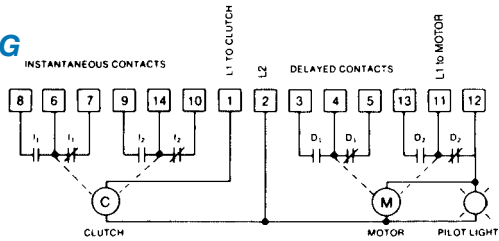

AC WIRING

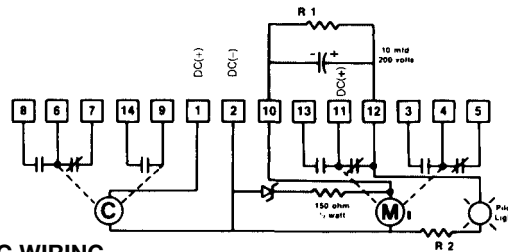

DC WIRING

CAUTION!: Power for motor must be jumped from Terminal 1 to 11. Do **NOT** apply power to Terminal 12.

UNIT RATING DC VOLTS	RESISTOR VALUES	
	R1	R2
48	800Ω	500Ω
125	4KΩ	30KΩ
250	10KΩ	150KΩ

Before starting your design, read the safety statement on the inside back cover of the ATC catalog.

ORDERING CODE

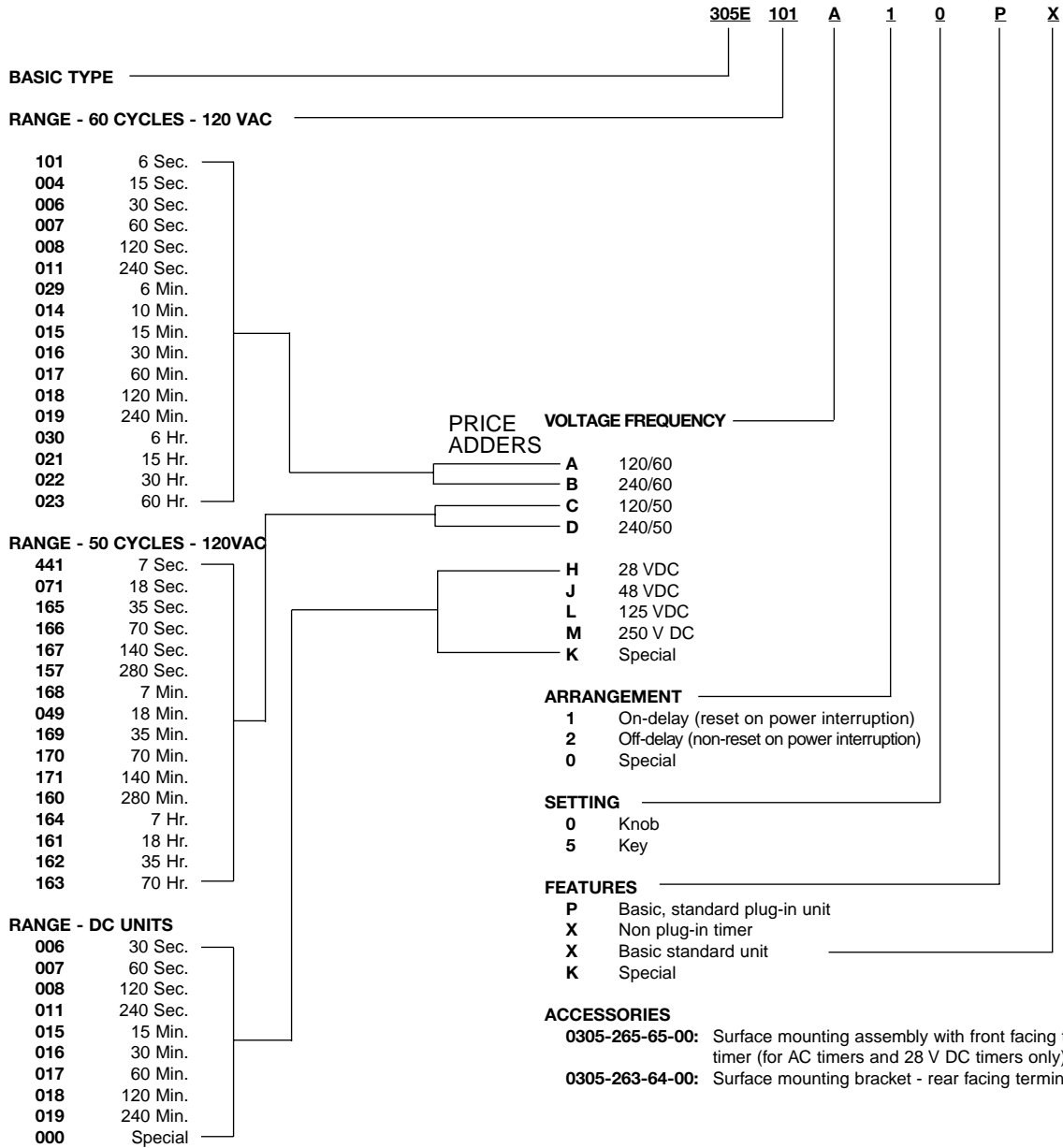

Before starting your design, read the safety statement on the inside back cover of the ATC catalog.