

Series 355

SHAWNEE II Digital GP Reset Timer



A compact version of the 335 Timer, the ATC 355 is its exact functional duplicate, packaged in a 72mm² DIN-Size housing, it occupies 40% less panel space and costs proportionately less. Modern production and assembly techniques have all but eliminated hand wiring, enhancing the reliability and life expectancy of the 355.

PRODUCT HIGHLIGHTS

COMPUTER TESTED RELIABILITY

The Solid-State 355 is manufactured from a series of computer-tested plug-in circuit boards and assembled virtually without hand wiring. Because it has no moving parts in its logic circuits, its life expectancy is practically unlimited. Even the load relay -- the 355's only significant mechanical component -- has a life expectancy of 100,000,000 operations (no load). As a result, the 355 achieves an overall reliability that surpasses even the high level achieved by previous Shawnee timers.

CYCLE PROGRESS INDICATION

The Shawnee indicating timer provides cycle progress indication on a four-digit display located immediately above the digital setting number wheels. While the non-indicating 355 does not provide true cycle progress indication, its pilot light can be wired so that it is **on** during the timing cycle.

PLUG-IN AND DUST-TIGHT

All 355 timers feature true plug-in design and can be replaced in seconds without disturbing the housing or disconnecting the wiring. The dial assembly is gasketed so that the timer body is dust-tight from the front of panel.



DIMENSIONS INCHES MILLIMETERS

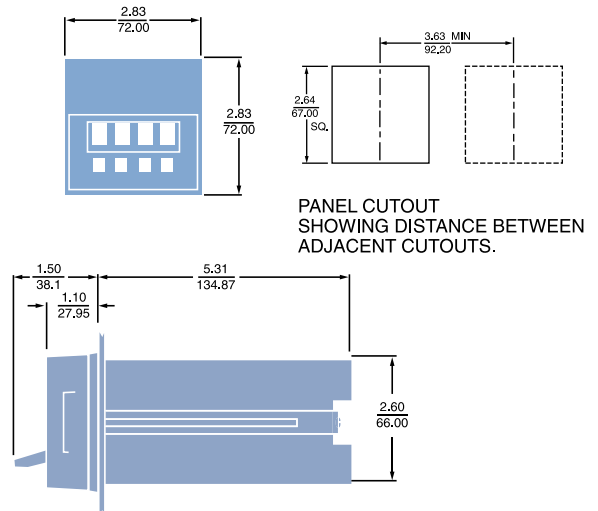

PANEL CUTOUT
SHOWING DISTANCE BETWEEN
ADJACENT CUTOUTS.

The 355B Directly Replaces 355A.

WIDE RANGE

Each Shawnee 355 timer covers the overall span of 0.01 sec to 999.9 min in two field-convertible ranges. The 355 indicating timer also offers two additional field-convertible ranges of 0.1-999.9 sec or min.

EASY TO SET AT ALL TIMES

The Shawnee timer is easily and accurately set even with work gloves on. Push any of its four toggle levers in any sequence until the number you want appears above it. You can decrease as well as increase each number by pushing the levers *up* or *down*. You can change the setting at any time, even during a cycle.

APPROVALS

See Agency Listing on page 391.

SAVE 40% IN PANEL SPACE AND COST

Packaged in a 72mm² DIN-size housing, the 355 occupies 40% less panel space than previous IC timers. Modern production and assembly techniques have substantially reduced manufacturing costs and resulted in a 45% cost saving.

OUTSTANDING REPEAT ACCURACY

Unsurpassed among industrial timers regardless of cost, the Shawnee has a repeat accuracy of ± 10 milliseconds on any setting within its overall range of 999.9 min., even in the face of wide swings in temperature or voltage and regardless of the amount of reset time between cycles.

NOISE IMMUNITY

The 355 does not have to be shielded: its transformer power supply, full-wave bridges, buffered logic and other design characteristics render it immune to the electrical noise that is encountered in typical industrial environments.

OPERATION

The Shawnee 355 operates on a digital logic circuit with three main elements: a *clock* which uses utility line frequency of 50 or 60 Hz as its time base; a *read-only-memory* (ROM) whose output is set by the timer's digital setting number wheels; and a *comparator* that continuously examines the outputs of the clock and ROM.

When power is applied (start signal **on**), two things happen simultaneously; the instantaneous DPDT relay is energized transferring both sets of contacts, and the clock circuit begins to count each cycle of the utility line frequency. Translating this count into hundredths of a second, the clock accumulates it and feeds it continuously to the comparator. When clock output exactly equals the output of the ROM, the comparator causes the 355 to time out.

At this point, (1) the DPDT delay relay is energized, immediately transferring both sets of contacts and (2) the clock turns itself off automatically. Since the clock stops counting even if the *start* signal remains **on**, it is not necessary to tie up one of the 355's delayed contacts to do this job.

To reset the Shawnee 355, power must be removed from terminal 1 (L1) for 75 milliseconds or more. The 355 operates in the **On-Delay** mode only, always resetting whenever there is a power outage and starting a new cycle when power is restored.

CYCLE PROGRESS INDICATION

When the timer is in the reset condition, the LED display is blank. During the timing cycle, the display counts up from zero, thus always indicating the amount of time that has elapsed since the start of cycle. At time-out, the display shows total elapsed time and exactly equals the numbers on the digital setting wheels.

SWITCHING SEQUENCE*				
RELAY	CONTACTS	Before Start	During Cycle	End of Cycle
INSTANTANEOUS	14-9/6-8	Gray	Blue	Gray
	14-10/6-7	Blue	Gray	Gray
DELAYED	11-12/4-5	Blue	Blue	Gray
	11-13/4-3	Gray	Blue	Blue

*Assumes a sustained closed start signal (i.e. longer that the setting on the digital display)

BLUE — Circuit Closed
 GRAY — Circuit Open

TYPICAL INSTALLATIONS

KEY SYMBOLS

- POWER SUPPLY
- CLOCK
- INDEPENDENT LOADS
- DEPENDENT LOADS
- MOMENTARY STARTING CONTACT
- SUSTAINED STARTING CONTACT
- LOAD ENERGIZED
- LOAD DE-ENERGIZED

All timers shown in "before start" position. Diagrams shown with power off unless otherwise marked.

Maximum load current through any load carrying contact is 5 amperes. Pilot lights leads are brought out to terminal block. Pilot light can be wired to show practically any desired function timer energized, cycle running, instantaneous or delayed switch closed, etc.

- DELAYED CONTACTS
Contacts transfer simultaneously when unit "times out" and all digits are zero.

- INSTANTANEOUS CONTACTS
Contacts are transferred when power supply is energized, transferred back as shown when de-energized.

SUSTAINED START

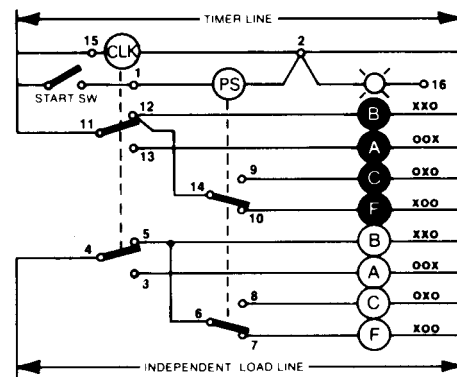

MOMENTARY START

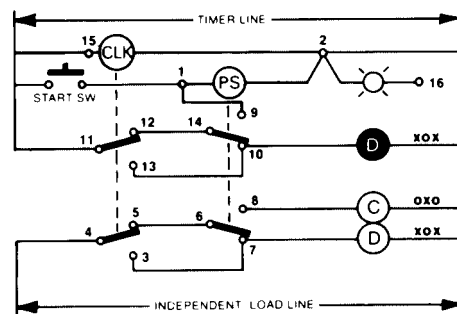

REPEAT CYCLE PULSE

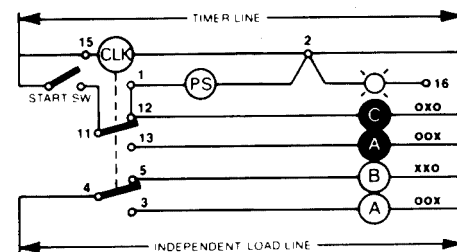

Load A pulses **on** for approximately 50mS

Wiring diagrams are shown for non-indicating models.

Before starting your design, read the safety statement on the inside back cover of the ATC catalog.

SPECIFICATIONS

MODELS

Both indicating and non-indicating models of the 355 are available. See ordering code.

CYCLE PROGRESS INDICATOR (indicating model only)

4 digit, 0.3 inch, high intensity, blue display.

RANGES

0.01 - 99.99 sec, 0.01 - 99.99 min, 0.1 - 999.9 sec, and 0.1 - 999.9 min; field-convertible.

REPEAT ACCURACY

±0.01 sec. on all ranges.

RESET TIME

75 milliseconds

MINIMUM SETTING

99.99 sec of min ranges: 0.01 sec or min, respectively.

999.9 sec or min ranges: 0.1 sec or min, respectively.

TIMING MODES POSSIBLE

SINGLE CYCLE: interval or delay

REPEAT CYCLE: pulse
(fixed at approx. 50 ms.)

LOAD RELAYS

NUMBER: two, one instantaneous and one delayed; both plug-in DPDT.

OPERATE TIME: 20 ms, max.

RELEASE TIME: instantaneous — 20 ms, max.

delayed — 75 ms, max.

CONTACT RATINGS: 5 A at 120V AC,

LIFE: 100 million operations (no load).

PILOT LIGHT

Non-indicating unit only. One pilot light.

Both leads brought out to terminal block.

TERMINALS

16 screw terminals accessible at rear; integral wiring diagram on housing.

HOUSING

Plug-in design; completely gasketed, dust-tight when panel-mounted.

POWER REQUIREMENTS

120V: 95-132V at 50 or 60 Hz

inrush — 0.2 A

running — 0.04 A

240V: 190-264V AT 50 OR 60 Hz

inrush — 0.1 A

running — 0.02 A

CLOCK INPUT:

Voltage — 95-132V rms (120V Model)
190-264V rms (240V Model)

Current — 20 mA max.

Frequency — 0 to 1000 Hz (sinusoidal)

TEMPERATURE RATING

32 TO 140°F (0 TO 60°C)

WEIGHT

NET: 1 lb., 7 oz.

SHIPPING: 2 lbs.

MOUNTING ACCESSORIES

STANDARD: Hardware is provided to mount timer so that it is dust-tight from front of panel.

OPTIONAL: Surface mounting without and with front-facing terminals.

(See Accessory section of catalog)

NEMA 12 case (1 timer)

WIRING

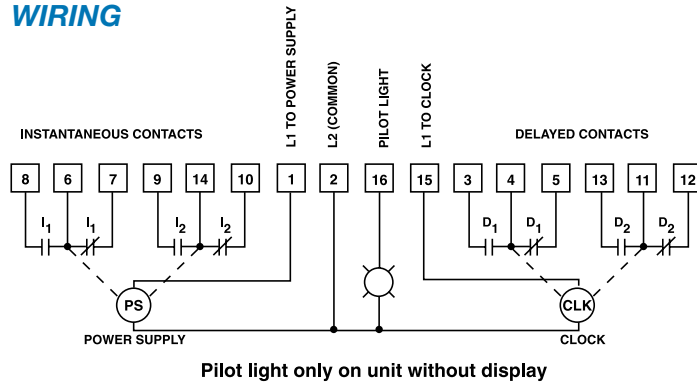

TERMINAL WIRING

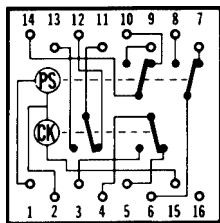

INDICATING MODEL

ORDERING CODE

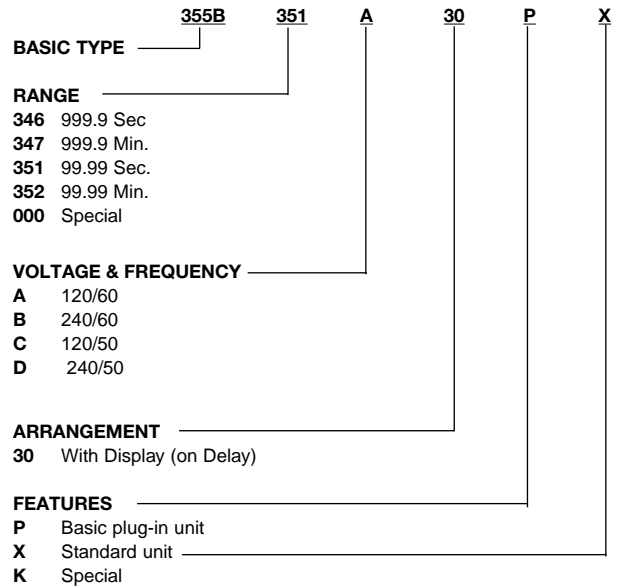

ACCESSORIES

0353-260-27-00 Surface mounting bracket kit

0305-265-61-70 Retrofit kit

For prices and further information, consult factory

The 355B Directly Replaces 355A.

Before starting your design, read the safety statement on the inside back cover of the ATC catalog.