

AL-800 Diaphragm Meter



Elster American Meter's aluminum case meters are designed to provide positive displacement accuracy for industrial or commercial loads.

Features

- Die-cast aluminum case
- Oil-impregnated, self-lubricating bushings
- Molded, convoluted diaphragms for smooth operation and long life
- Rigid, reinforced flag rods for positive alignment and sustained accuracy
- Graphite-filled phenolic valves to minimize wear
- Long-life, low friction, grommet seals
- Single coat polyester primer with high solids polyurethane top coat
- Security seals that indicate tampering

Advantages

- AMR/AMI Compatibility
- Temperature Compensation available from -30°F to 140°F (-34°C to 60°C)
- Meets ANSI B109.2 specifications
- Measurement Canada accredited
- 800 SCFH (22.7m³/h) (0.60 specific gravity gas) at 1/2-inch W.C. differential

Applications

The AL-800 meter is ideally suited for commercial and industrial installations. It is unequalled for accuracy retention and for life cycle maintenance economies.

Options

- Regular or Temperature Compensated
- Pointer or odometer index
- 5ft³, 10ft³, or 0.1m³ drive
- 30LT, 45LT, 60LT, 100LT, 1-1 1/2" NPT and other connection sizes
- Pressure compensating indexes
- Standard or UV protected index covers
- Remote volume pulsers
- Connection sets
- 20 or 100PSIG (140 or 6895 mbar) Maximum Allowable Operating Pressure (MAOP)



elster
American Meter

AL-800 Diaphragm Meter

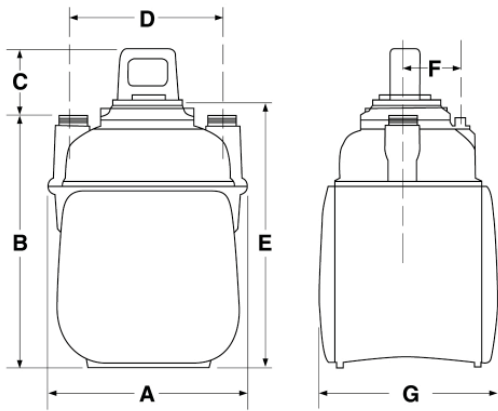

Dimensions - Inches (mm)

MAOP (psig)	A	B	C	D	E	F	G	Weight (lbs.)	Connections
20	14.12 (359)	18.50 (470)	4.81 (122)	11.00 (279)	19.12 (486)	4.38 (111)	13.25 (337)	50	1-1/4"–30 LT 1-1/2"–45 LT #3-4 Sprague
20	14.12 (359)	19.19 (487)	4.19 (106)	11.00 (279)	19.12 (486)	4.38 (111)	13.25 (337)	50	1-1/2" NPT (F)
100	14.62 (372)	18.75 (476)	5.19 (132)	11.00 (279)	19.75 (502)	4.38 (111)	16.62 (422)	70	1-1/2" NPT (F)

Capacities (0.60 specific gravity gas)

Line Pressure PSIG (mbar)	Differential Inches W.C. (mbar)	SCFH (m ³ /h)
0.25 (17)	1/2 (1.2)	800 (22.7)
0.25 (17)	2 (5)	1700 (48.1)
5 (345)	2 (5)	2100 (59.5)
10 (690)	2 (5)	2600 (73.6)
15 (1035)	2 (5)	2800 (79.3)
20 (1379)	2 (5)	3200 (90.6)
25 ¹ (1724)	2 (5)	3500 (99.1)
30 ¹ (2069)	2 (5)	3800 (107.6)
50 ¹ (3447)	2 (5)	5100 (144.4)
75 ¹ (5171)	2 (5)	6500 (184.1)
100 ¹ (6895)	2 (5)	7800 (220.9)

1 - 100 psig model only

About Elster Group

A world leader in advanced metering infrastructure, integrated metering, and utilization solutions to the gas, electricity and water industries. Elster's metering and system solutions reflect over 170 years of knowledge and experience in measuring precious resources and energy.

Elster provides solutions and advanced technologies to help utilities more easily, efficiently and reliably obtain and use advanced metering intelligence to improve customer service, enhance operational efficiency, and increase revenues. Elster's AMI solutions enable utilities to cost-effectively generate, deliver, manage, and conserve the life-essential resources of gas, electricity, and water.

Elster has a staff of over 7,500 serving customers globally in North America, Central America, South America, Europe, Asia, Africa and the Middle East.

ISO 9001:2000



Certification No. 006697

Elster American Meter
2221 Industrial Road
Nebraska City, NE
68410
USA

T +1 402 873 8200
F +1 402 873 7616

www.elster-americanmeter.com

Elster Canadian Meter

T +1 905 634 4895
F +1 905 634 6705

www.elster-canandianmeter.com

© 2009 Elster American Meter. All right reserved

EAM-DS3817-EN-P - September 2009