

Photoelectrics

Retro-reflective, Polarized

Type PA18C.P..., DC

CARLO GAVAZZI

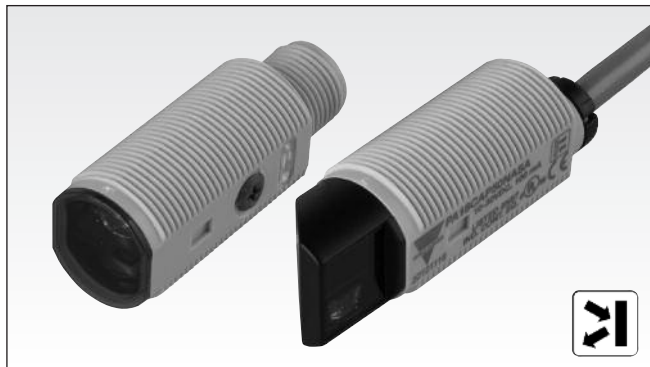

- Miniature sensor range
- Range: 5 m (axial), 4 m (radial)
- Sensitivity adjustment by potentiometer
- Modulated, red light 625 nm
- Supply voltage: 10 to 30 VDC
- Output: 100 mA, NPN or PNP, N.O & N.C.
- Degree of protection: IP67, IP69K
- LED indication for output, stability and power ON
- Protection: reverse polarity, short circuit and transients
- Cable and plug versions
- Excellent EMC performance



Product Description

The PA18C.P is part of a family of inexpensive general purpose retro-reflective sensors in industrial standard 18 mm cylindrical ABS housing. The sensors are useful in applications where high-accuracy detection as well as small size is required.

Compact housing and high power LED for excellent performance-size ratio. The potentiometer used for adjustment of the sensitivity makes the sensors highly flexible. The output type is NPN or PNP and the output switching function is NO and NC.

Ordering Key

PA18CAP05PAM1SA

Type	_____
Housing style	_____
Housing size	_____
Housing material	_____
Housing type axial	_____
Detection principle	_____
Sensing distance	_____
Output type	_____
Output configuration	_____
Connection type	_____
Sensitive adjustment	_____

Type Selection

Housing style	Range S_n	Connection	Ordering no. NPN Make & break switching	Ordering no. PNP Make & break switching
M18 Axial type	5.0 m	Cable	PA 18 CAP 50 NASA	PA 18 CAP 50 PASA
M18 Axial type	5.0 m	Plug	PA 18 CAP 50 NAM1SA	PA 18 CAP 50 PAM1SA
M18 Radial type	4.0 m	Cable	PA 18 CRP 40 NASA	PA 18 CRP 40 PASA
M18 Radial type	4.0 m	Plug	PA 18 CRP 40 NAM1SA	PA 18 CRP 40 PAM1SA

Specifications according to EN60947-5-2

Rated operating distance (S_n) Axial type (A) Radial type (R)	Up to 5.0 m, Up to 4.0 m Reference target: ER4 reflector \varnothing 80 mm	OFF-state current (I_r)	$\leq 100 \mu A$
Blind zone	100 mm	Voltage drop (U_d)	≤ 2.0 VDC @ 100 mA
Sensitivity control Adjustable distance to target Axial types Radial types	Adjustable by potentiometer 270° 50-500 cm 50-400 cm	Protection	Short-circuit, reverse polarity and transients
Temperature drift	$\leq 0.2\%/^{\circ}C$	Light source	InGaAlP, LED, 625 nm
Hysteresis (H) (differential travel)	$\leq 20\%$	Light type	Red, modulated
Rated operational volt. (U_B)	10 to 30 VDC (ripple included)	Sensing angle	$\pm 2^{\circ}$
Ripple (U_{rpp})	$\leq 10\%$	Ambient light	30.000 lux Incandescent lamp
Output current Continuous (I_a) Short-time (I)	≤ 100 mA ≤ 100 mA (max. load capacity 100 nF)	Light spot Diameter	$\varnothing 150$ mm @ 2.5 m
No load supply current (I_o)	≤ 20 mA @ 24 VDC	Operating frequency	500 Hz
Minimum operational current (I_m)	0.5 mA	Response time OFF-ON (t_{ON}) ON-OFF (t_{OFF})	≤ 1.0 ms ≤ 1.0 ms
		Power ON delay (t_v)	≤ 300 ms
		Output function Type Switching function	NPN or PNP NO and NC
		Indication Output ON Signal stability and power ON	LED, yellow LED, green

Specifications are subject to change without notice (25.02.2011)

1



Specifications (cont.)

Environment		Housing material	
Installation category	III (IEC 60664/60664A; 60947-1)	Body	ABS, grey
Pollution degree	3 (IEC 60664/60664A; 60947-1)	Front material	PMMA, red
Degree of protection	IP 67, IP 69K*	Connection	
Ambient temperature		Cable	PVC, grey, 2 m 4 x 0.25 mm ² , Ø = 4.5 mm
Operating	-25° to +60°C (-13° to +140°F)	Plug	M12, 4-pin (CON. 54-series)
Storage	-40° to +70°C (-40° to +158°F)	Weight	With cable: 40 g With plug: 10 g
Vibration	10 to 55 Hz, 0.5 mm/7.5 g (IEC 60068-2-6)	CE-marking	Yes
Shock	30 g / 11ms, 3 pos, 3 neg per axis (IEC 60068-2-6, 60068-2-32)	Approvals	cULus (UL508) supply class 2
Rated insulation voltage	500 VAC (rms) IEC protection class III		

* The IP69K test according to DIN 40050-9 for high-pressure, high-temperature wash-down applications. The sensor must not only be dust tight (IP6X), but also able to withstand high-pressure and steam cleaning. The sensor is exposed to high pressure water from a spray nozzle that is fed with 80°C water at 8'000– 10'000 KPa (80–100bar) and a flow rate of 14–6L/min. The nozzle is held 100 –150 mm from the sensor at angles of 0°, 30°, 60° and 90° for 30s each. The test device sits on a turntable that rotates with a speed of 5 times per minute. The sensor must not suffer any damaging effects from the high pressure water in appearance and function.

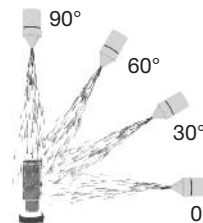

Operation Diagram

tv = Power ON delay

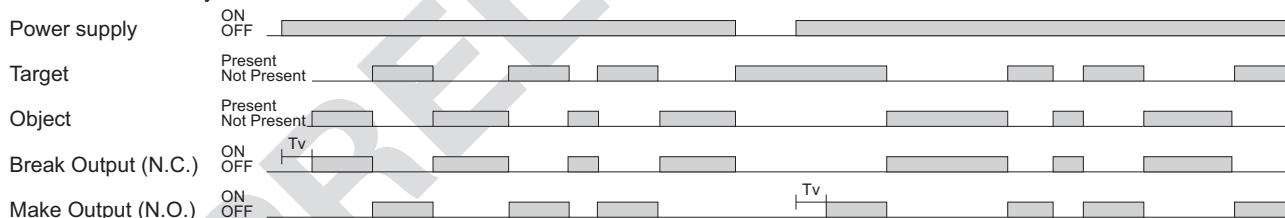

Wiring Diagrams

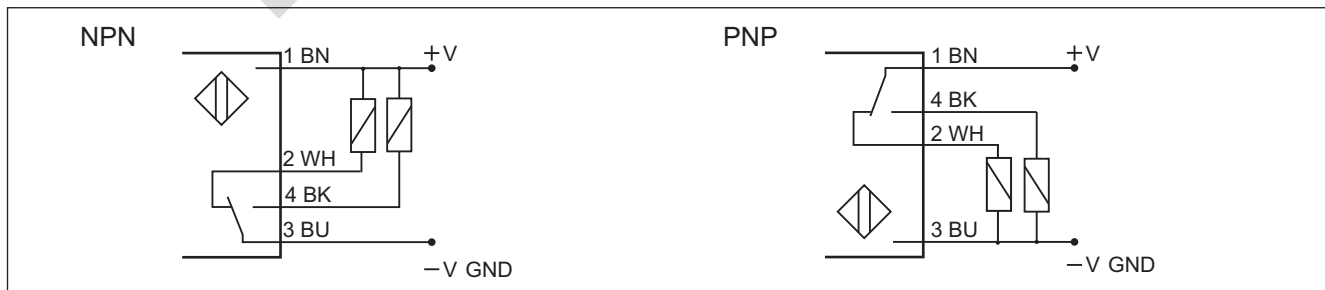

Detection Diagram

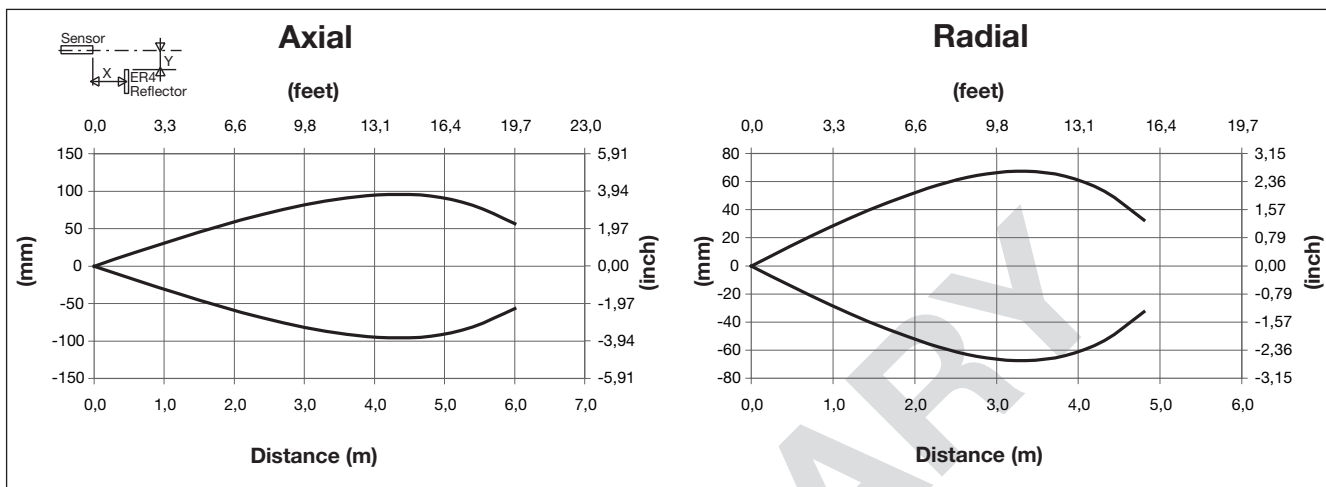

Excess Gain

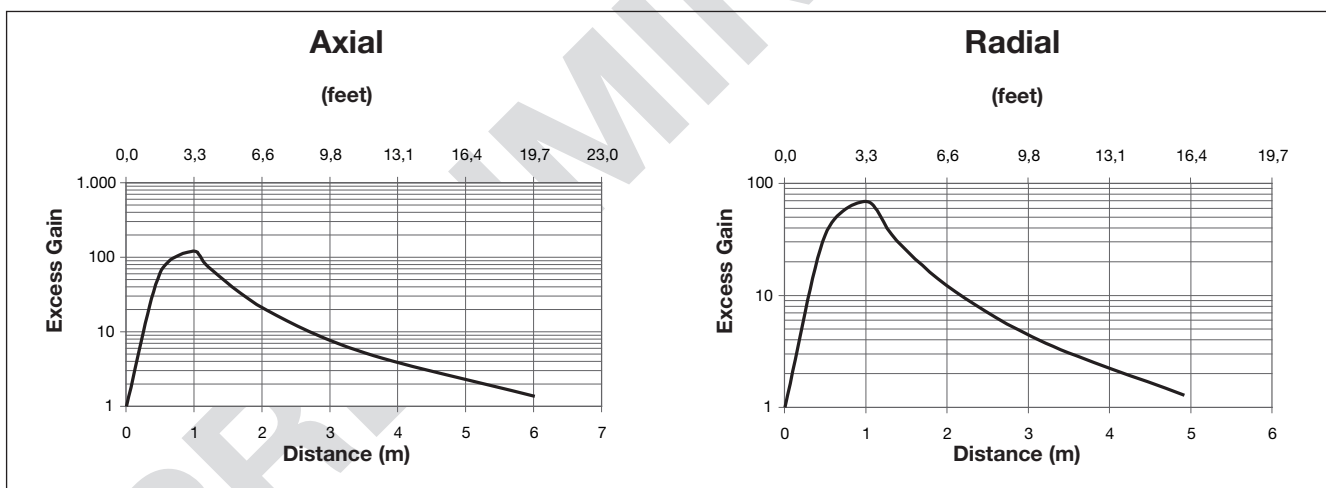

Signal Stability Indication

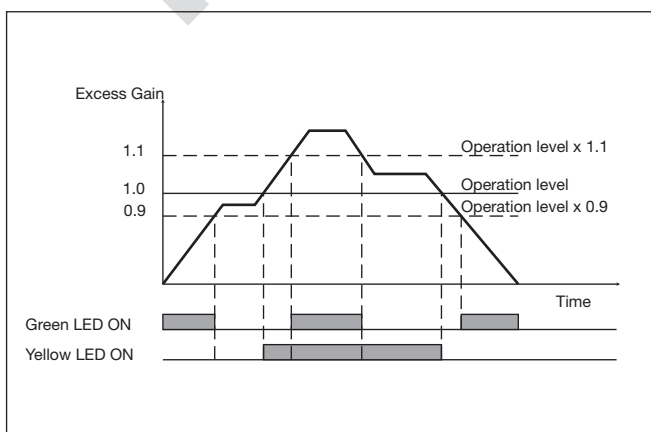

APA 18-MB1

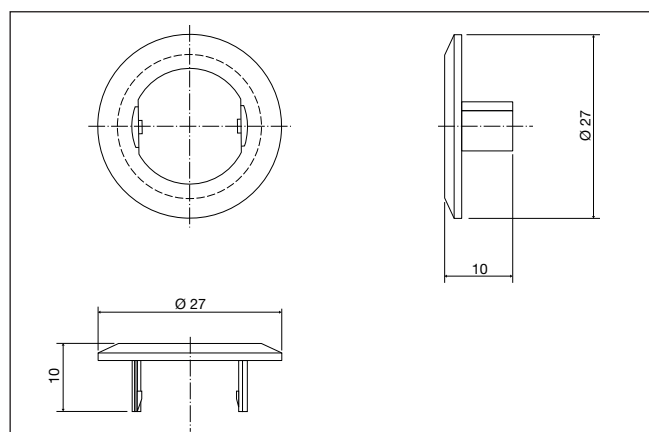



Dimensions Radial version

Cable version

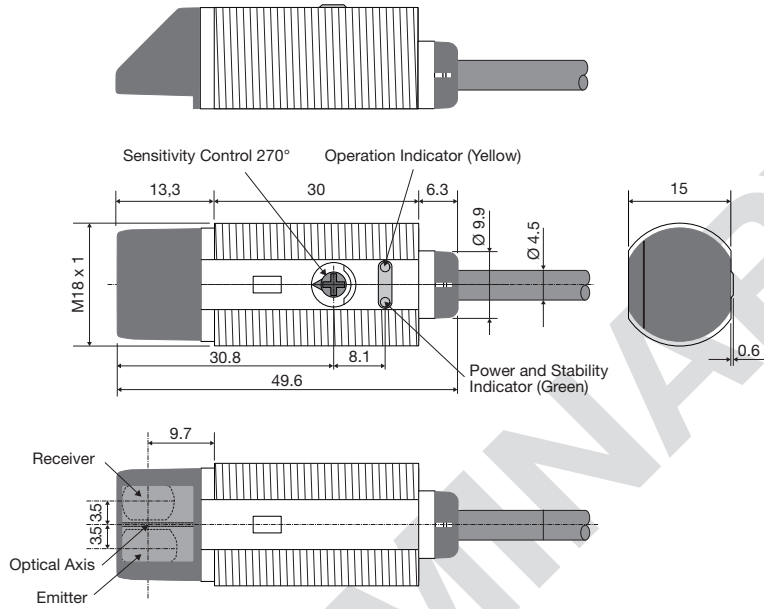

Plug version

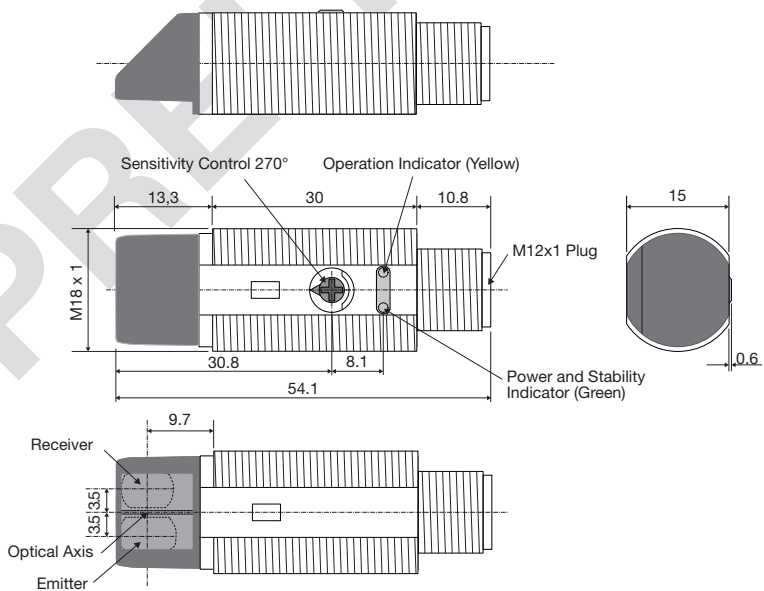



Dimensions Axial version

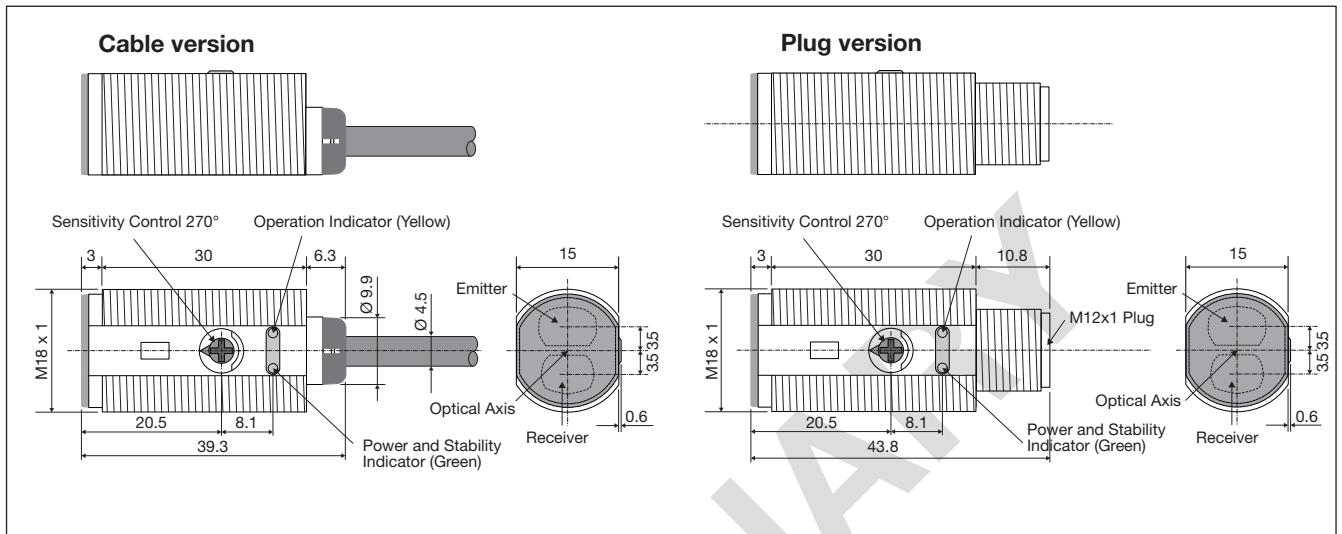

Mounting Systems

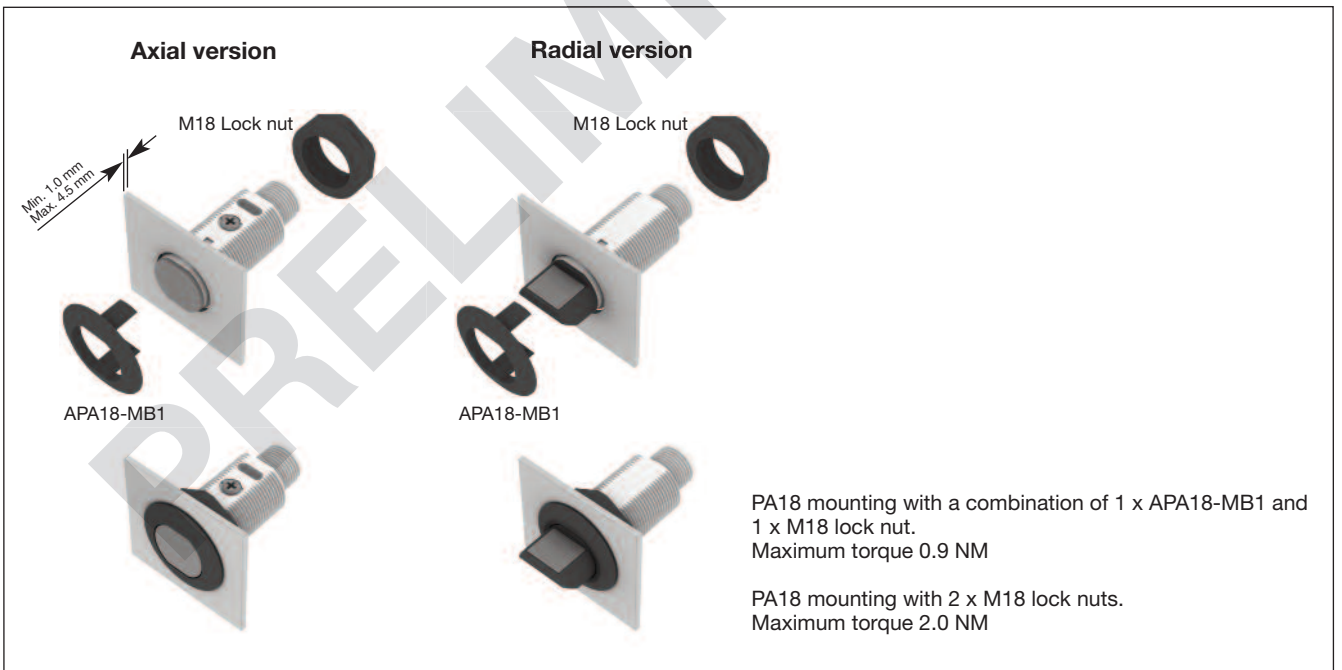

Installation Hints

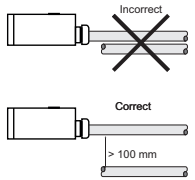
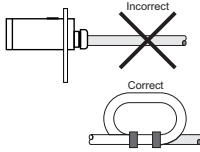
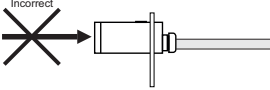
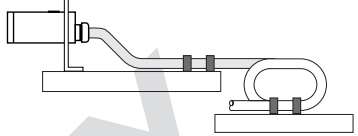
<p>To avoid interference from inductive voltage / current peaks, separate the proximity switch cables from any other power cables. E.g. Engine, contactor or solenoid cables</p>  <p>Incorrect</p> <p>Correct</p> <p>> 100 mm</p>	<p>Relief of the cable strain</p>  <p>Incorrect</p> <p>Correct</p> <p>The cable should not be pulled</p>	<p>Protection of the sensing face</p>  <p>Incorrect</p> <p>A proximity switch should not serve as mechanical stop</p>	<p>Sensor mounted on a mobile carrier</p>  <p>Any repetitive flexing of the cable should be avoided</p>
---	---	--	--

Delivery Contents

- Photoelectric switch: PA 18 C.P..
- Installation instruction on plastic bag
- Screwdriver
- Mounting bracket APA18-MB1
- 2 M18 lock nuts
- **Packaging:** Plastic bag

Accessories

- Connector type CONG1A.. / CONM14NF.. series
- Reflector type ER.. - to be purchased separately